

<THESE INSTRUCTIONS MUST BE GIVEN TO THE END USER>



B&W Trailer Hitches
 1216 Hawaii Rd / PO Box 186
 Humboldt, KS 66748
 P:800.248.6564
 F:620.869.9031

Call or Email us for
 Installation Support
 hitches@turnoverball.com
 bwtrailerhitches.com

See Limited Lifetime Warranty at
bwtrailerhitches.com/warranty

Turnoverball® Gooseneck Hitch Installation Instructions

MODEL 1320

2019-2024 RAM 2500 & 3500 Trucks

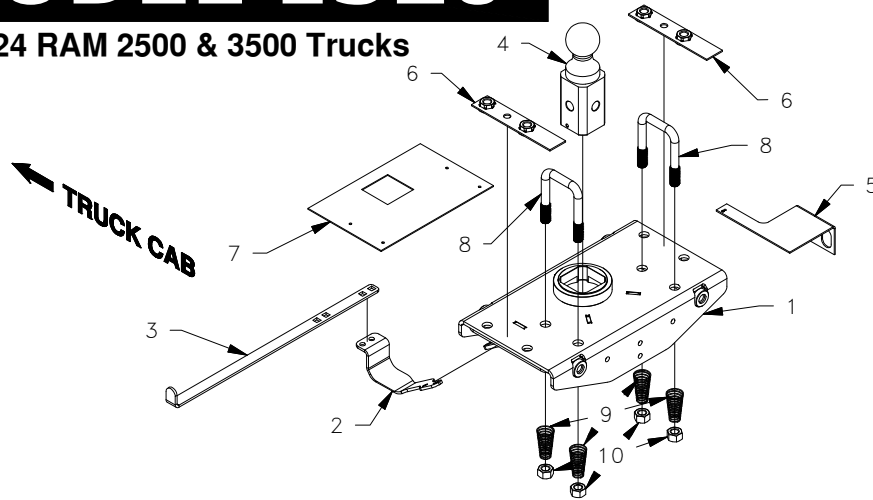

PARTS LIST (GNRK1320)		
ITEM	DESCRIPTION	QTY
1	Center Section	1
2	Latch Pin Handle Bracket	1
3	Latch Pin Handle	1
4	2-5/16" Ball	1
5	Hole Template	1
6	Fastener Block	2
7	Safety Chain U-bolt Guide	1

Hardware Kit Bolt Bag		
ITEM	DESCRIPTION	QTY
8	5/8" x 2-1/2" x 4" U-Bolt	2
9	Conical Spring	4
10	5/8" Center Lock Nut	4
	5/8" x 1-1/2" Locking Cap Screw	8
	3/8" x 1" Carriage Bolt	4
	3/8" Locking Flange Nut	4

Installation instruction note: Diagrams used in these installation instructions show representations of RAM 2500 truck components. RAM 3500 trucks will vary in appearance but have similar installation procedures.

ATTENTION: If you intend to use an 18K Companion 5th Wheel RV Hitch model 3000 in conjunction with this hitch, an adapter kit is needed to fill voids in the truck bed rib pattern. Call B&W at 800-248-6564 for a kit that will adapt the hitch to the truck bed, or upgrade to a hitch base that will not require the adapter kit (models 3500, 3400, or 3405). Using the model 3000 without the adapter kit could result in damage to the truck bed. B&W recommends placing the coupler of the Companion 5th Wheel Hitch as close to the cab as possible while still maintaining adequate turning clearance between the truck and trailer.

⚠ WARNING

Failure to comply with the safety information in these instructions could result in serious injury or death.

- ⚠ Read all installation and operating instructions along with all labels before using this product.
- ⚠ Adding components such as a Turnoverball hitch to the chassis of any vehicle can be hazardous. There is potential for unexpected combustion of fuel, electric shock, burns, shifting or falling of unstable vehicle, damage to vehicle, injury from tool usage and many other hazards. This installation must be completed by someone who is aware of the hazards involved. This person must be knowledgeable of proper safety procedures for a vehicle modification of this nature, and for usage of the equipment required to perform the installation.
- ⚠ Without proper knowledge, towing can be a dangerous activity. Understand all the risks involved with towing before proceeding. For information on towing safety, see "**The Trailer Handbook: A Guide to Understanding Trailer and Towing Safety**" from the National Association of Trailer Manufacturers, www.NATM.com and your trailer manufacturer's owner's manual.
- ⚠ Do not exceed tow or tongue rating of coupler, tow or tongue rating of hitch, or tow or weight ratings of truck or trailer. See vehicle and trailer manufacturer information for ratings. Exceeding these ratings may cause damage to towing components or loss of attachment between the trailer and truck.
- ⚠ Do not modify this product in any manner. Doing so could alter its integrity and lead to a loss of attachment between the trailer and the tow vehicle.
- ⚠ Additional caution must be used when towing a wedge car trailer. Towing stability greatly depends on keeping the center of gravity as low as possible. Load heavy cars over the axles. Never tow with a single car on the front of the trailer. When towing a wedge car trailer, never exceed speeds that are reasonable for the roadway conditions (e.g. turns, going around a curve, etc.). Failure to account for proper trailer center of gravity and speeds that are reasonable for the roadway conditions may cause damage to the truck, trailer, towing components, and loss of attachment between the truck and trailer.
- ⚠ This product was designed to fit vehicles in their original, "as manufactured" condition. Compatibility with vehicles having replacement parts, or other modifications is not guaranteed. Inspect vehicle for modifications before installation of this product.
- ⚠ The Turnoverball hitch comes equipped with a 2-5/16" ball. Trailers towed with the ball provided must have a 2-5/16" coupler. Towing with a larger coupler could cause loss of attachment between the trailer and the tow vehicle.
- ⚠ A visual inspection of the hitch should be performed before each time you tow. Regularly check that all pinned connections are secure, and that all bolted connections are at the correct torque specification. Check for cracks or damage to the hitch. Do not tow with the hitch if cracks or damage outside of normal wear is found. Towing with a hitch that has cracks or damage could result in damage to the tow vehicle, trailer, towing components and loss of attachment between the tow vehicle and trailer.

PREPARE TO INSTALL

NOTICE: In some instances, the ball should **NOT** be turned over and stowed in the socket. Doing so could cause damage to the truck's suspension. If the truck's suspension has a stabilizer between the top of the differential housing and the frame, as shown in Figure A1, the stowed ball could hit the stabilizer, damaging the truck's suspension.

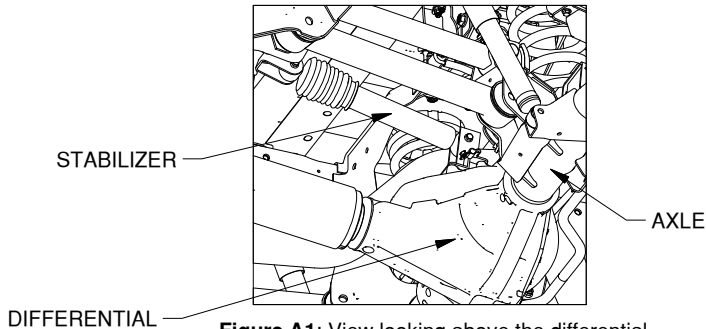

Figure A1: View looking above the differential from in front of the driver side rear tire.

NOTE: Remove all parts from the packaging and familiarize yourself with all the parts and tools required. Use the parts list on the front page to verify that all parts and hardware are present.

TOOLS REQUIRED

- Impact wrench or ratchet with 10mm, 9/16", & 15/16" sockets.
- Marking tool (pencil or permanent marker)
- 3-1/2" hole saw
- Drill with 11/16" & 1/4" bits
- Ear protection
- Lifting device
- Tape measure
- Pry bar & Soap and water
- Socket extensions & swivel socket
- Flashlight
- Eye protection
- Torque wrench
- Center punch
- C-clamp
- Ratchet strap

1. **Determine cab clearance.** Under the truck bed, measure from the rear most vertical face of the C-channel frame cross member (over the axle) to the end of the bed, see Figure A2, Length A. Next, inside the bed, measure the length of the bed from the rear edge to the front, see Figure A2, Length B. Subtract the cross member measurement (Length A) from the bed measurement (Length B). Then subtract an additional 5-3/4" inches. This will give you the measurement from the center of the 2-5/16" ball location to the cab. Measure the distance from the center of the trailer's coupler to the farthest forward corner point of the trailer. Compare this distance to the measurement from the center of the 2-5/16" ball location to the cab. These measurements will allow you to see how much clearance you will have between the cab and the trailer while towing and turning, see Figure A3.

WARNING: Cab clearance on short bed trucks is very limited when towing certain trailers. Failure to ensure that there will be adequate clearance, may result in significant property damage, or serious injury.

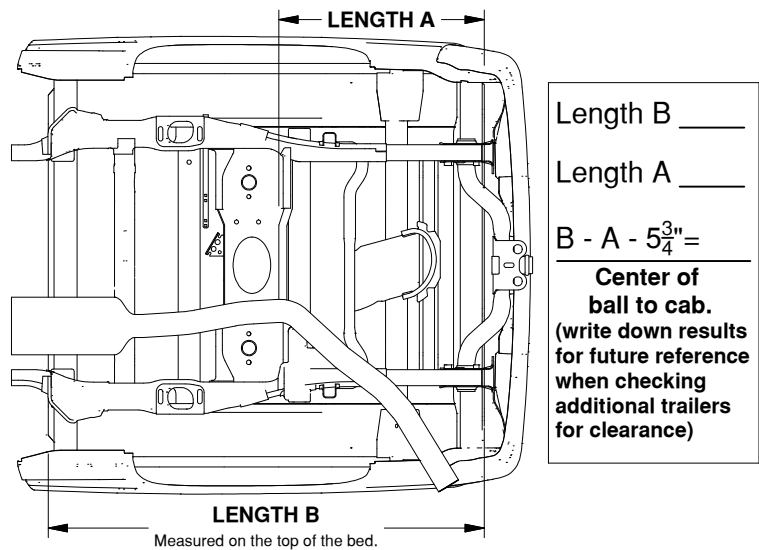

Figure A2: View of bottom of truck. (3/4 ton truck shown)

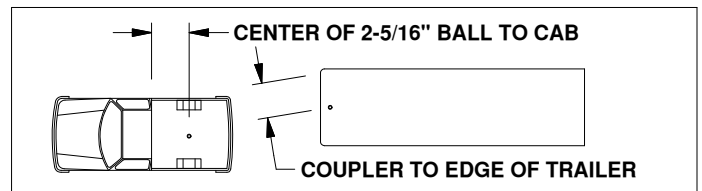

Figure A3: Truck and trailer diagram.

2. **Remove the spare tire (optional).** Following the vehicle manufacturer's instructions, remove the spare tire. This will provide easier access to the area where the hitch will be installed.
3. **Remove the heat shield (optional).** Remove the bolts connecting the heat shield to the frame and set the heat shield aside for later installation.
4. **Position the vehicle.** Installation of the hitch requires the installer to be under the truck bed in the area of the rear axle. Lifting the vehicle makes this area more accessible to the installer, and improves the installation process.

WARNING: Lift vehicle using only equipment designed for lifting and positioning vehicles for service. Failure to do so may result in property damage, serious injury, or death.

5. **Prepare a lifting device (optional).**

The purpose of the device is to safely hold the hitch in position during part of the installation. See Figure A4 for an example.

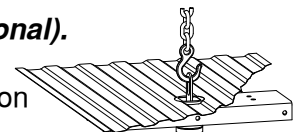

Figure A4

A simple mechanical lifting device is available for purchase from B&W.

6. **Remove fender liners as needed.** Some vehicles are equipped with various designs of plastic liners inside the rear wheel wells. If the liner in the driver side wheel well prevents access to the opening between the bed and the frame, just over the axle, it may need to be temporarily removed for handle installation.

7. **Disconnect the exhaust hanger.** Locate the exhaust hanger in the rear passenger portion of the truck. Disconnect the exhaust from the hanger to provide improved mounting access to the center section. It is recommended that a pry bar be used to aid in disconnecting the exhaust hanger, as shown in Figure A5. Using soap and water to lubricate the pin and the rubber hanger may aid in disconnection.

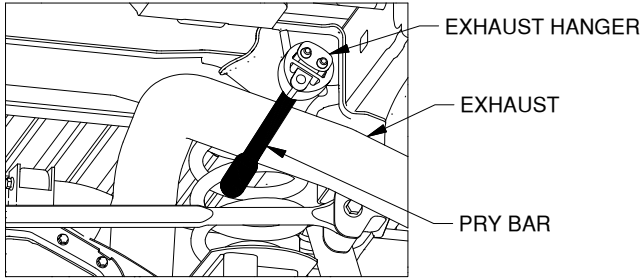
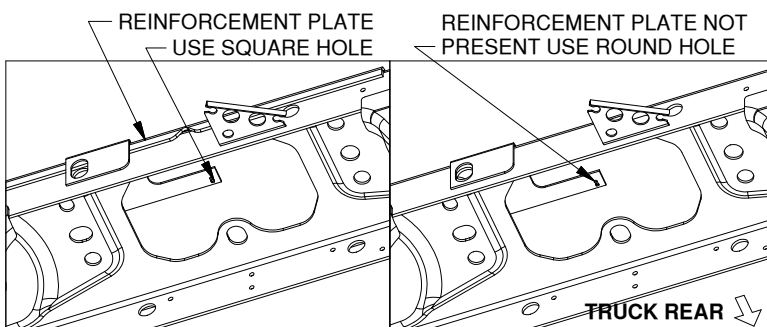

Figure A5: View looking under truck bed towards cab.

8. **Mark the location of the 3-1/2" hole.** Locate the hole marking template. The template will allow the drill location for the 3-1/2" hole to be marked. First, position the hole marking template above the frame cross member, as shown in Figure A7. Before the hole can be marked the template will need to be correctly positioned. Push the template up against the bottom of the truck bed. Move the template back until the formed flange is flat against the forward flange of the cross member. Slide the template so that the oval hole in the flange is in line with the hole in the cross member. Clamp the template to the flange in the cross member when the template is correctly positioned. There are two options for marking the center of the 3-1/2" hole. One location represented by the small round hole and one by the small square hole. The square hole is only for certain 3500 trucks with reinforcement plates welded to the frame cross member. These plates add one thickness of material to the cross member where the template references from. All other trucks with only one material thickness on the cross member will use the round hole. See Figure A6. Make a mark on the truck bed floor through the hole in the hole template using a marker, or other tool. Once the center point is marked, remove the template. Use a center punch to place an indentation in the truck bed at the center of the mark. Using a drill and a 1/4" bit, drill a pilot hole through the bed in this location.



3500 TRUCK WITH REINFORCEMENT PLATES 3500 TRUCK WITHOUT REINFORCEMENT PLATES

Figure A6: View looking under truck bed at cross member.

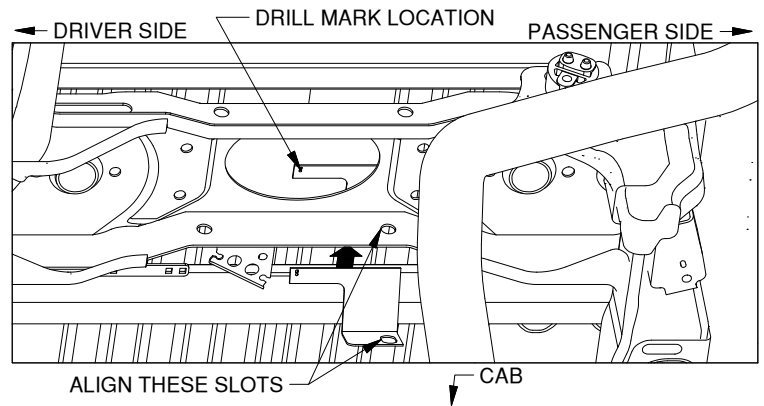

Figure A7: View looking under truck bed towards cab. (Axle not shown)

9. **Cut the 3-1/2" diameter hole.** From the top side of the bed, use the pilot hole and a hole saw to create a 3-1/2" diameter hole in the truck bed floor. A saber saw equipped with a metal cutting blade may also be used if the 3-1/2" diameter circle is laid out on the bed floor around the center of the pilot hole. Remove any burrs created while cutting the hole. Do not allow any burrs to remain on the bottom side of the hole.

INSTALL CENTER SECTION

- ⚠ **CAUTION:** Turnoverball hitch components are heavy and may be cumbersome to handle. Failure to use proper lifting techniques and caution when handling these items could result in serious injury.
- ⚠ **WARNING:** Most trucks have fuel lines, brake lines, electrical wires or other vehicle systems located along the frame rails or in the general area where B&W Turnoverball hitches install. Carefully examine the locations of these systems before installation. Make certain that these are not damaged during positioning hitch components, drilling holes, or tightening fasteners. Damage to these systems may result in property damage, serious injury, or death.

1. **Remove plastic fasteners.** Before installing the center section, pull out any plastic fasteners attached to the rear flange of the frame cross member in the area where the center will install. These will be secured in a later step, see Figure B1.

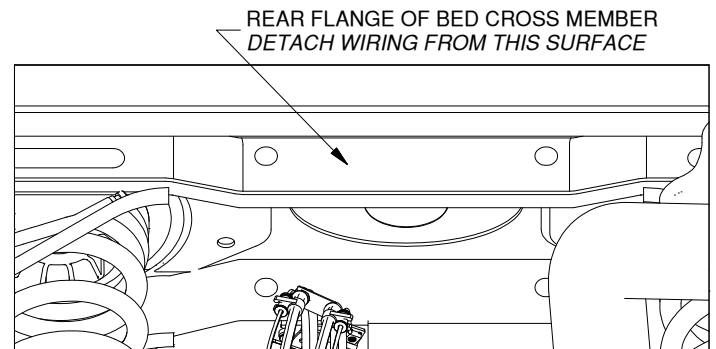

Figure B1: View looking under truck bed towards cab.

2. **Position fastener blocks.** Locate the two fastener blocks. These will be installed between the bed and the top of the frame cross member so that the flanges of the nuts are down against the cross member and centered over the hitch mounting holes. These may be installed from the front or rear of the frame cross member. Figure B2 shows the install from the rear. The space between the bed and the frame cross member is very limited. The nuts must pass over the frame cross member while they are each in a different high rib of the truck bed. There is a slight depression in the frame cross member that allows more room for the nuts once they are on top of the cross member. Once the nuts are on top of the frame cross member, the fastener block can be rotated so that the nuts line up with the holes.

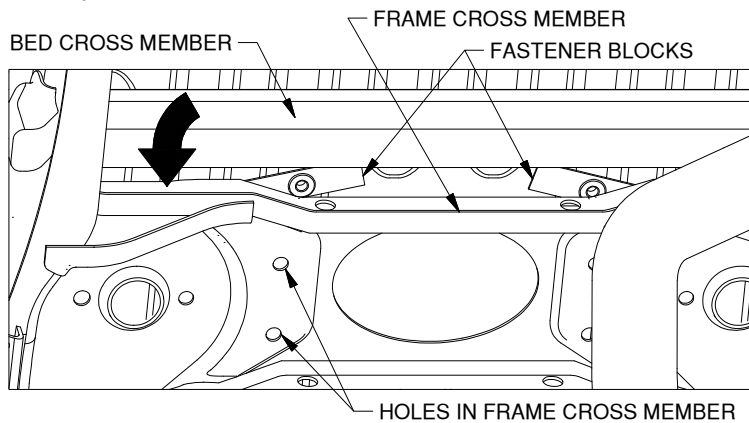

Figure B2: Looking under truck bed towards cab.

NOTICE: On gas trucks the exhaust will need to be pulled over towards the driver side of the truck to allow tool access to the bolts on the passenger side of the truck. On diesel trucks the exhaust will need to be pulled straight down to allow the center to fit over the exhaust for installation. Use secure methods to hold the exhaust if working alone. As an example: a ratchet strap connected to the exhaust and to the driver side of the frame or the axle.

3. **Position the center section.** With the latch pin mechanism on the driver side, raise the center section into place, as shown in Figure B3. In order to clear structures under the truck bed, the center will have to be lifted into place on an angle over the exhaust, then positioned directly under the frame cross member so that the raised portion of the center can be pushed straight up through the hole in the bed. Start a 5/8" flange head bolt through each hole in the forward and rear flanges into the threaded bushing in the center to hold the center in place. Next, while keeping the fastener blocks from rotating, install a 5/8" flange head bolt into each of the four holes under the fastener blocks until they are snug but not fully tight, see Figure B4.

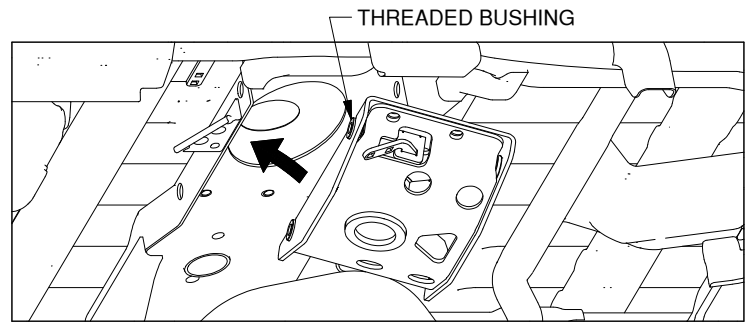

Figure B3: Looking up at bed from in front of driver side tire.

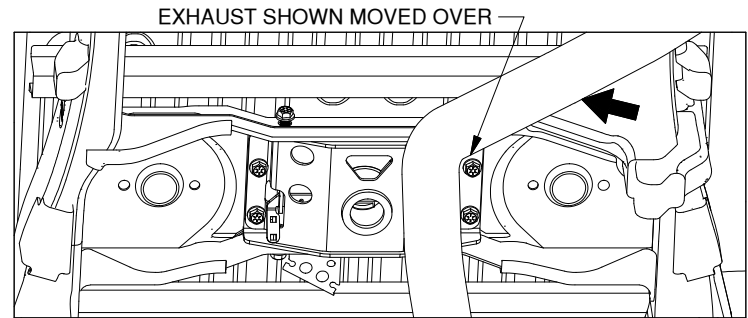

Figure B4: Looking up at frame cross member under truck.

4. **Check hitch position.** Check the location of the hitch socket inside the 3.5" hole in the bed. The socket should be aligned directly in the center of the hole. Rotate the hitch so that it is parallel to the flanges in the frame cross member. When the hitch is parallel to the cross member the gaps between the threaded bushings and the flanges of the frame cross member will be the same on the passenger and driver sides. The hitch must not be touching the brake lines that are anchored to the frame cross member.
5. **Tighten the 5/8" bolts.** While keeping the center section square, tighten and torque the four 5/8" bolts which are threaded into the fastener blocks to 150 ft. lbs. Next, tighten the four 5/8" bolts in the forward and rear cross member flanges. The bolt on the forward flange on the driver side has limited access. A ratchet extension and swivel joint may need to be utilized. Once tightened, torque the bolts to 150 ft. lbs.
6. **Secure plastic fasteners.** Replace the plastic fasteners that were pulled from the holes in the rear flange of the bed cross member.

INSTALL LATCH PIN HANDLE

- 1. Move wiring for handle install.** The handle may come into contact with part of the wiring harness running over the driver side of the frame, see Figure C1. Move the wire from this area of the frame by pulling the wiring down beside the frame in the inside of the truck. In some cases, fasteners may be present that will need to be pulled out of the frame. A wire tie may need to be used to keep the wire down out of the way of the handle. When correctly installed, no moving part of the handle should rub on any wires in your truck.

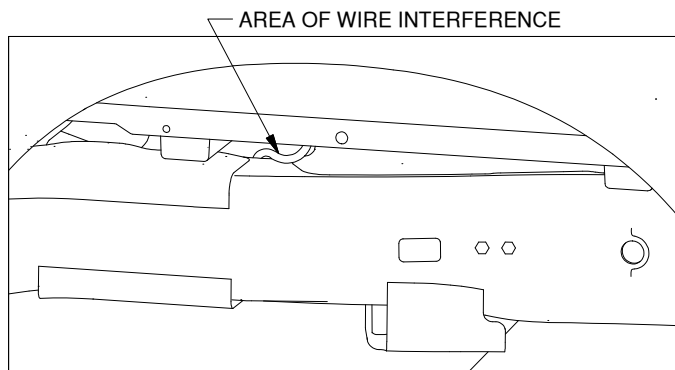
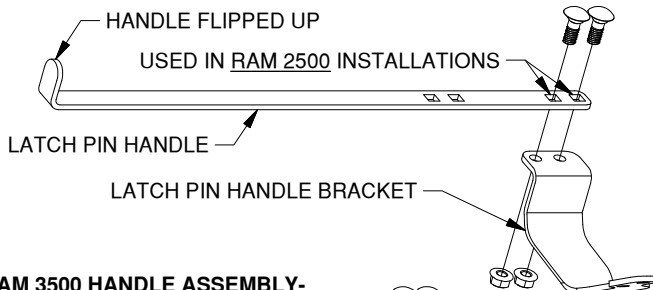

Figure C1: View looking into the driver side wheel well.

- 2. Assemble the handle.** Locate the latch pin handle and the latch pin handle bracket. The handle has two assembly configurations. The holes at the end of the handle are for installation in RAM 2500 trucks. In this configuration the handle will be flipped up. The holes that are about 4 inches from the end are for RAM 3500 truck installations. In this configuration the handle will be flipped down. Assemble the pieces of the handle with two 3/8" carriage bolts and 3/8" locking flange nuts, making sure that the edge of the handle is in line with the edge of the bracket, see Figure C2. Torque the nuts to 30 ft. lbs.

-RAM 2500 HANDLE ASSEMBLY-



-RAM 3500 HANDLE ASSEMBLY-

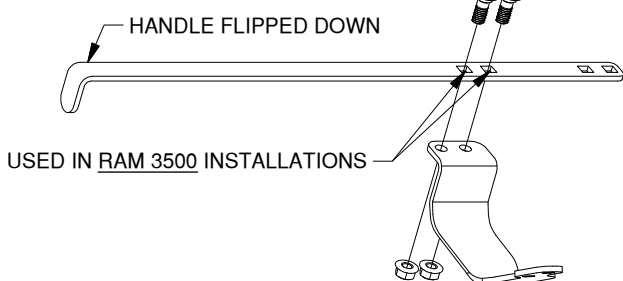

Figure C2: Latch handle assembly configurations.

- 3. Install bolts.** Retract the latching mechanism in the center section by pulling on the tab with the square holes and pushing it toward the cab. From the top down, insert a 3/8" carriage bolt in each of the square holes in the latching mechanism.

CAUTION: Serious injury can occur due to the pinch point located at the intersection of the latching mechanism and the center section.

- 4. Position the latch pin handle.** Beginning under the vehicle "thread" the end of the handle in front of the brake lines and over the frame on the driver side.

- 4a. 2500 RAM handle installation.** Once the handle is past the bed flange, as shown in Figure C3, move to the outside of the truck. The handle will need to be pulled under the plastic fender liner. Pull up on the bottom edge of the liner until it is possible to pull the handle out past the fender liner.

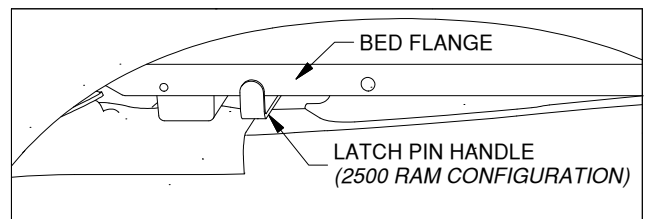

Figure C3: View looking into driver side wheel well.

- 5. Install the latch pin handle.** Attach the handle to the latching mechanism over the 3/8" carriage bolts with two 3/8" locking flange nuts, see Figure C4. Be sure that the handle is in the proper position and that it does not interfere with any other components of the vehicle. It may be necessary to adjust the handle position by loosening the 3/8" nuts and re-positioning the handle. Torque the nuts to 30 ft. lbs. to secure the handle.

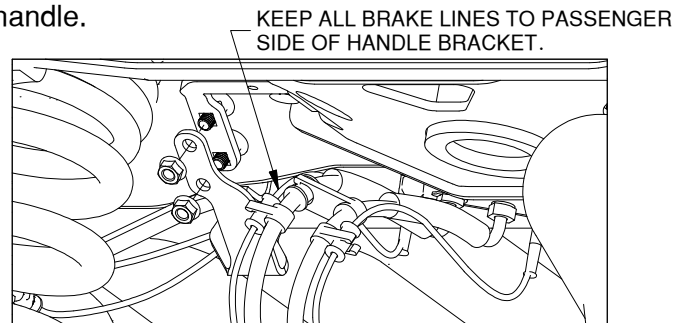

Figure C4: Looking up at frame cross member under truck.

NOTICE: The latch handle must be positioned on the "cab side" of the brake lines directly over the axle.

- 5a. 3500 Ram Handle installation.** The handle may be difficult to locate under the plastic fender liner, making a small cut out in the area above the handle may improve handle visibility.

- 6. Secure Wiring.** The handle mechanism may contact the sensor wires that run along the brake lines in the area above the differential. Tie the wires down to the brake lines with a wire tie or other secure method to avoid damage to the wires, see Figure C4.

INSTALL SAFETY CHAIN U-BOLTS

This Turnoverball hitch is equipped with holes in the center section for mounting safety chain U-bolts.

1. **Drill the holes.** Use the Safety Chain U-bolt Guide to mark the four hole locations in the truck bed. From the top of the bed drill each hole with a 11/16" drill bit. Two of the holes will go through both the frame cross member and the bed. A small pilot hole will aid in drilling through the bed and cross member. Be sure to drill the holes perpendicular to the surface of the bed. It is possible to drill the holes from under the bed if necessary.
2. **Install the U-bolts.** From the top side of the truck bed, drop a U-bolt in each set of holes.
3. **Add springs.** Place a conical spring over each leg of the U-bolts and secure with a 5/8" lock nut, see Figure D1. Tighten the lock nut until the nut is flush with the end of the U-bolt.

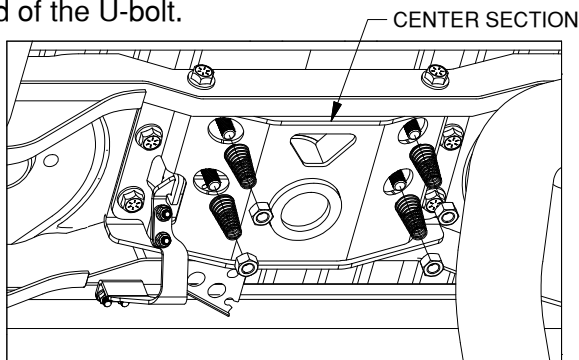

Figure D1: Looking up at frame cross member under truck.

INSTALL FRAME STICKER

1. **Place handle sticker.** Locate the latch handle sticker provided with your instruction packet. Apply the sticker to the frame in the driver side wheel well. Align the left edge of the sticker with the latch handle and top and bottom edges of the sticker with the frame.

PREPARE FOR TOWING

1. **Re-attach exhaust bracket.** If the exhaust was un-attached, pull the exhaust back up to the exhaust bracket and re-attach. We recommend using soap and water to lubricate the "pin" and the rubber hanger which attach the exhaust hanger to aid in re-attachment.
2. **Replace spare tire and heat shield.** If the spare tire and/or the heat shield were removed prior to installing the hitch, replace it at this time.
3. **Modify fender liner.** If a fender liner is present that restricts the movement of the handle, it is recommended that it be modified by cutting a relief slot or hole to allow the handle to move freely. If the liner was removed for installation, reinstall at this time.
4. **Retract the pin.** Pull the handle out all the way until it stops then slide it toward the cab. The handle should stay in this position. The latch should only be put in this open position when inverting the 2-5/16" ball or installing a B&W towing accessory.

WARNING: Operating the tow vehicle while the latch is in the open position may allow the handle to come into contact with the rear tire. This may damage the tire or the handle and could lead to serious injury or death.

5. **Lubricate 2-5/16" ball.** Apply a light coating of grease to the corners on the square shank of the 2-5/16" ball.
6. **Check latch pin engagement.** When installed properly, the latch pin should pass through both sides of the ball socket. With the ball removed, push handle toward the rear of the truck until the handle retracts and the latch pin engages. Visually inspect the ball socket and verify the latch pin has passed completely through both walls of the socket. Make a mark on the latching mechanism where indicated in Figure F1 to show where the latching mechanism should be when the pin is correctly positioned in the ball socket. Retract the pin, replace the ball, and re-engage the pin. Check the marked location on the latching mechanism. If the mark is in the same location as when the mark was made, then the latch pin has gone completely through the ball socket.

WARNING: Failure of the pin to engage the ball and hitch properly could result in a loss of attachment between the trailer and the tow vehicle

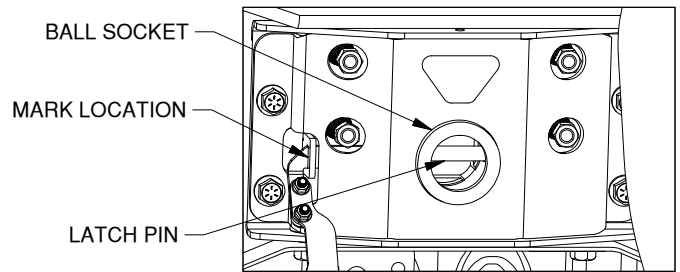

Figure F1: View under bed looking up at center section.

WARNING: Inverting the ball while hauling heavy loads may cause the ball to strike the truck's differential, drive line, or other components. Inspect the relationship between the ball and truck components to ensure the proper clearance. Failure to remove the ball when hauling heavy loads may result in property damage, injury or death. A cover to prevent debris from entering the socket while operating without the ball in place is available from B&W.

7. Re-read all warnings on front page of these instructions. If you are not the end user, make sure that users of this product receive a copy of these instructions.